

The Messy Meter

## Solar Oven S'mores

In this activity, kids will learn about how engineers harness the power of solar energy. Kids will use tin foil to convert energy from the sun into conductive heat to cook s'mores in a cardboard box.

This activity requires access to an outdoor space. For optimal results try it when the sun is most intense. The higher angle the sun, the faster you get your s'more!

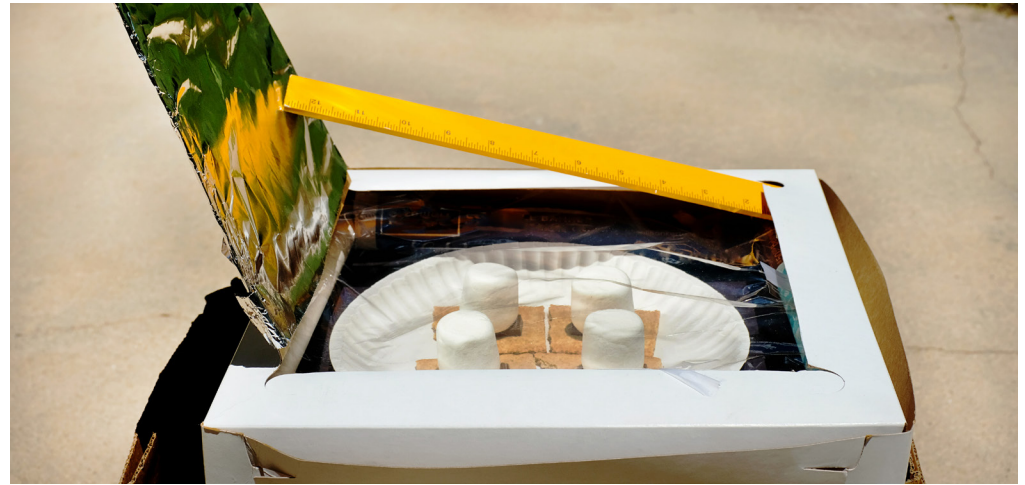

Recommended Grades:  
**3 - 6**

Estimated Time:  
**1 Hour**

Subject:  
**Solar Power**

### WHAT YOU'LL NEED

- Small cardboard box with a lid, such as a Pizza box
- Tin foil
- Graham crackers
- Marshmallows
- Chocolate
- Plastic wrap
- Sunlight
- Pencil/stick or wood skewer
- A very hot day

### OPTIONAL ADD-ONS:

- Tape

### STEPS

1. Take an empty pizza box and cover the base and lid with tin foil all the way around – depending on your pizza box and your foil, you may need tape to securely fasten the foil. Be careful to make as few wrinkles as possible. This will reflect the solar radiation into the box so the more concentrated the light, the better.
2. Next, place the box outside. Ideally, try to place the box on a concrete surface like your driveway or sidewalk.
3. Orient the solar cooker directly towards the sun so that there's no shadow inside the cooker. The shadow of the cooker should be directly behind its back.
4. Cover the opening of the box with plastic wrap; this will help keep the heat inside your solar box. Make sure that it is completely sealed.
5. Use a pencil, stick or skewer to play with the position of the pizza box lid, you want to be using the lid to direct more sun rays directly into the pizza box. Take a look at the diagram to help determine the best position for the lid.
6. Allow the box to “pre-heat” in this position for 30 minutes.
7. Once the box is finished preheating, place your graham crackers, with marshmallows on top, inside the box and reposition the lid to catch those sun rays. (Don't add the chocolate just yet!)
8. Let the s'mores cook for approximately 30 minutes.
9. Once the marshmallows are soft, place the chocolate on top and reposition the lid for 5 more minutes.
10. Finally, carefully remove the s'mores from the box and enjoy!

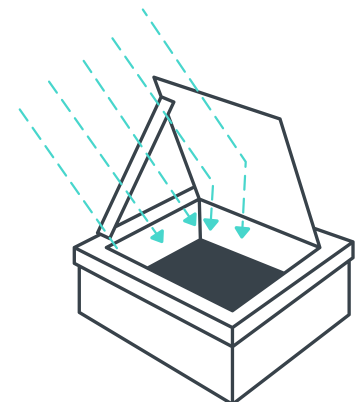

### Bonus Fun:

Experiment with engineering a structure to support your solar cooker. Using standard printer paper and tape design a structure for your solar cooker to live on and compare the time it takes for the s'mores to cook in the different structures.

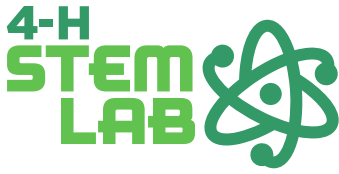

---

### Questions to Engage Youth:

How do you think tin foil helps cook the s'mores?

Why does the entire box need to be covered in tin foil?

Why do you think it takes so long to cook them in the sun vs. at a campfire?

Why should you place the box on a concrete surface instead of grass?

How does preheating the box help the s'mores cook?

What are some ways you could make the s'mores heat up faster?

---

### Explanation:

You can use sunlight to cook food! The aluminum foil on the box lid concentrates the sun rays reflecting them into your cooker. Your food is heating up because of the interaction between sunlight and the aluminum foil. When the sunlight hits the aluminum some of the energy is converted from light energy to heat energy. Because aluminum foil is a metal, it conducts heat easily and your food begins cooking. Your cooker is able to retain the energy created through this process because the plastic wrap is covering the main body of the cooker, keeping the heat inside. So, you can use it to trap solar energy and use that energy to cook food. Aluminum is just one of several types of conductive materials. Other common ones include copper, steel, and nickel. It's also very malleable, which means you can bend it into many different shapes.

Using solar energy to make s'mores is one way to harness the sun's power. But solar power can be used for much more. Today you learned how to use aluminum foil to create a small solar thermal energy system. The sun can also interact with other materials to directly create electricity through solar photovoltaic cells - more simply, in solar panels - we can use the sun's energy to power cars, heat swimming pools, and even provide electricity to our homes through solar panels on the roof.

### Career Connections:

If you enjoyed working with aluminum and using the sun's power to make s'mores, then you might be interested in becoming a solar engineer. **Solar engineers** develop, test, and install solar panels and other solar-powered technologies. They often work in laboratories and outdoors at solar power plants. Solar engineers are highly trained in the field of solar energy, but many have backgrounds in mechanical and electrical engineering.

---

Brought to you by:

